

Montaje Soporte Maleta lateral



Nota:

No apriete todos los tornillos hasta que no estén completamente alineadas todas las perforaciones con respecto a los puntos de sujeción.

Antes de realizar la instalación, verifique todo el manual e identifique que las partes y las piezas estén completas.

Herramientas:

Kit llaves hexágonas

Kit llaves Torx





Kit Instalado

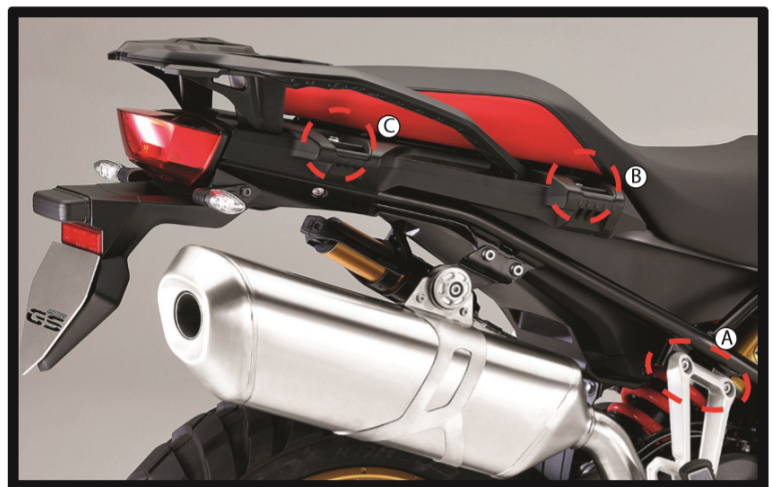

Instalación

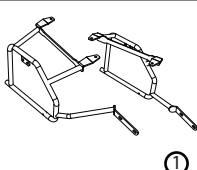
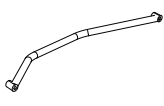
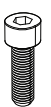

El Kit Contiene

<p>Protector Carenaje Derecho/Izquierdo</p>  <p>1</p> <p>Cantidad: 1 c/u</p>	<p>Platina sujeción Central</p>  <p>2</p> <p>Cantidad: 1</p>
<p>Socket M8x30</p>  <p>3</p> <p>Cantidad: 4</p>	<p>Socket M8x45</p>  <p>4</p> <p>Cantidad: 2</p>

1. Retire los calapiés traseros de la moto (A) para instalar los puntos mostrados en (A).
2. Retire la tornillería de la moto en los puntos (B) y (C) respectivamente para instalar los kit de tornillería (4) y (3) según diagrama.
3. Por último, instale el tubo trasero en puntos (D) con Kit de tornillería (3)

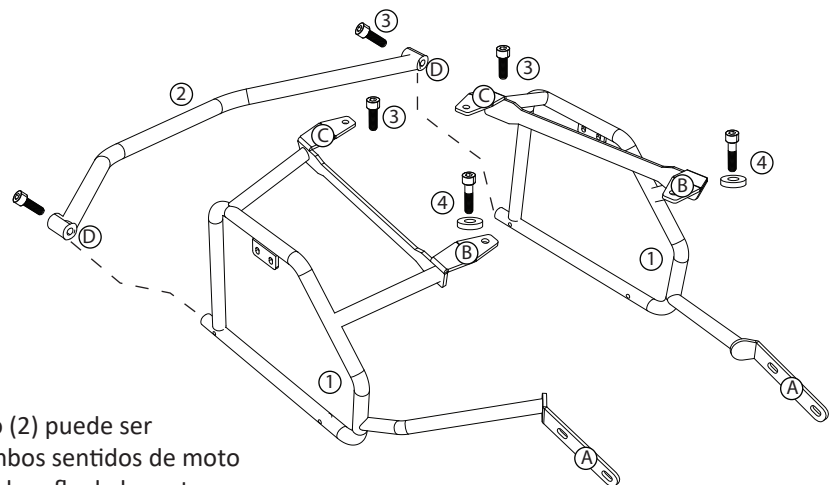

¡IMPORTANTE:
El tubo Trasero (2) puede ser instalado en ambos sentidos de moto que no toque el moñe de la moto

Al terminar la instalación de las partes, verifique que estén alineadas y que toda la tornillería esté debidamente apretada; reajuste todos los tornillos.

Assembly Instructions side Pannier Rack

Note :

Do not tighten the screws until they are completely aligned with the holes.
Before the installation, please verify through the manual that all pieces and parts are complete.

Tools Required:

Hex Allen Wrench Set

Torx Wrench Set





Assembled Kit

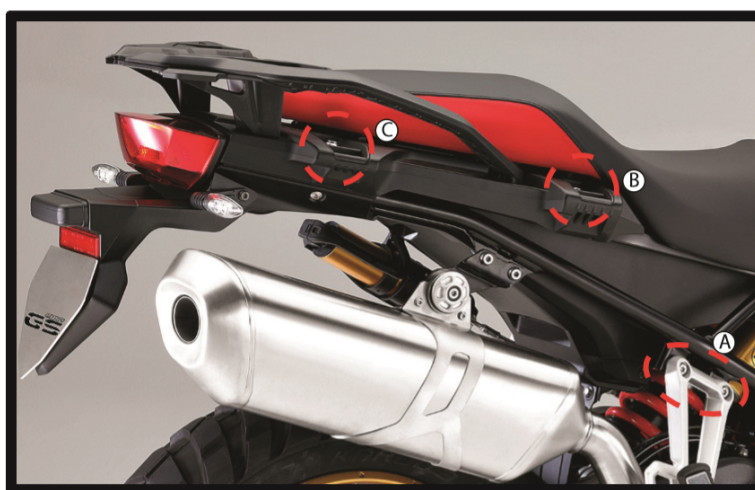

Installation

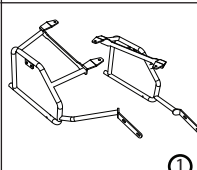
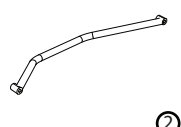
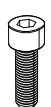

instalaion Kit

<p>Pannier Rack Righth/Left</p>  <p>Qtty: 1 RH/LH</p>	<p>Rear Pannier Rack</p>  <p>Qtty: 1</p>
<p>M8x30 Socket Screw</p>  <p>Qtty: 4</p>	<p>M8x45 Socket Screw Aluminum Spacer</p>  <p>Qtty: 2</p>

1. Remove the Foot Pegs of the motorcycle (A), and install in (A) to the Side Pannier Racks.
2. Remove the motorcycle Screws at (B) and (C) points, install the hardware kit (4) and (3) according to diagram.
3. Finally, install the rear Pannier Rack in (D) points with hardware kit (3).

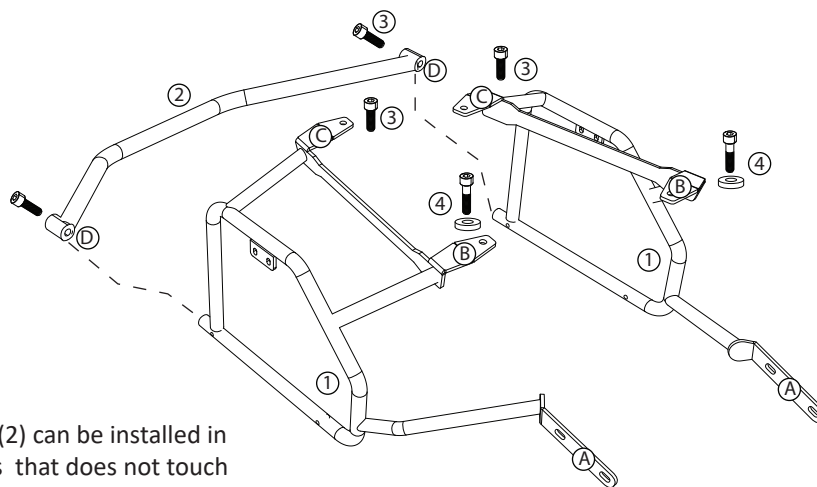

IMPORTANT:

The Rear tube (2) can be installed in both directions that does not touch the muffler of the motorcycle.

After the installation of the parts, please check that they are aligned and that all the hardware is properly tightened