

### NOTA:

No apriete los tornillos hasta que no estén completamente alineadas las perforaciones con respecto a los puntos de sujecion indicados.

Antes de realizar la instalación, verifique todo el manual e identifique que las partes y las piezas esten completas.

### HERRAMIENTAS:

Llaves boca fija      Llavele hexagonas

Raches

















Copas

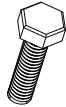

### PRODUCTO INSTALADO



### EL KIT CONTIENE:

Crashbar lateral derecho 	Crashbar lateral izquierdo 	Platina sujecion superior 	Platina sujecion inferior 	Tornillo socket M8X20 
CANTIDAD: 01	CANTIDAD: 01	CANTIDAD: 01	CANTIDAD: 01	CANTIDAD: 04
Punta inyectada 	Platina sujecion No 2 inferior 	Arandela plana M8 	Arandela plana M6 	Tornillo hexagonal M8X30 
CANTIDAD: 02	CANTIDAD: 01	CANTIDAD: 04	CANTIDAD: 02	CANTIDAD: 02
Tuerca de seguridad M8 	Tuerca de seguridad M6 	Tornillo socket M6X20 	Tuerca de seguridad M5 	Tornillo socket M5X210 
CANTIDAD: 04	CANTIDAD: 02	CANTIDAD: 02	CANTIDAD: 08	CANTIDAD: 08
Tornillo button M6X40 	Arandela de caucho M6 	Tuerca M6 INOX 		
CANTIDAD: 02	CANTIDAD: 02	CANTIDAD: 02		

### INSTALACIÓN:

- 1 Utilice los siguientes puntos de sujecion indicados en la **Imagen 1** para realizar el montaje del producto.



Imagen 1.

- 2 Utilice los puntos de sujecion indicados en la **Imagen 1** para realizar el montaje de los componentes segun se muestra en el **Esquema 1**.

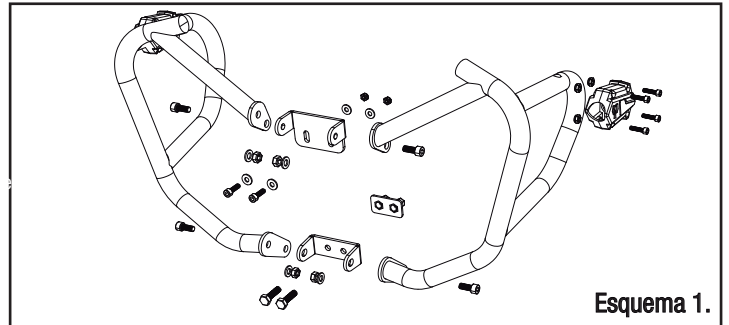

Esquema 1.

- 3 Instalar el producto segun lo muestra el **Esquema 1**, producto completamente ensamblado en **Esquema 2**.

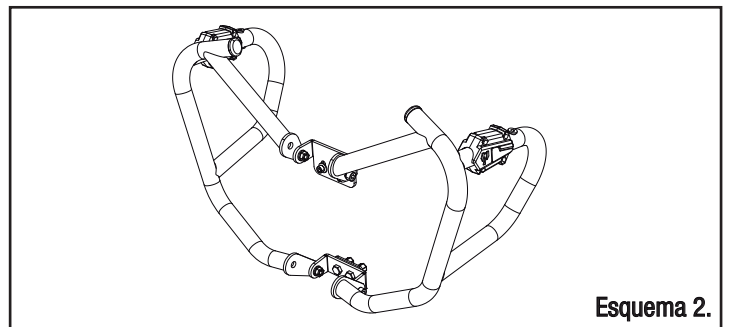

Esquema 2.