



## MANUAL DE INSTALACIÓN PN008316



## DEFENSA TRIUMPH SPEED 400 / SCRAMBLER 400

### NOTA:

No apriete los tornillos hasta que no estén completamente alineadas las Perforaciones con respecto a los puntos de sujeción indicados.

Antes de realizar la instalación, verifique todo el manual e identifique que las partes y las piezas estén completas.

### HERRAMIENTAS:





Rache (X2)   
 copa #14, 17 

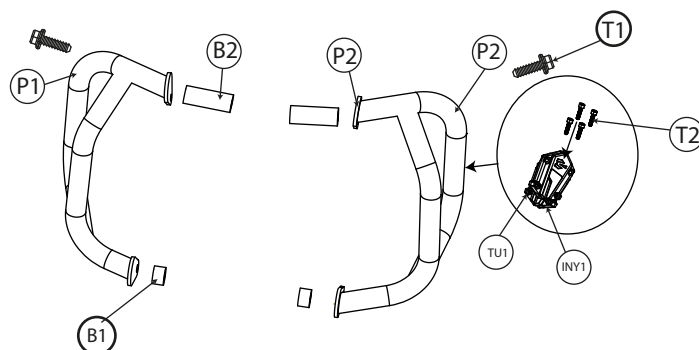
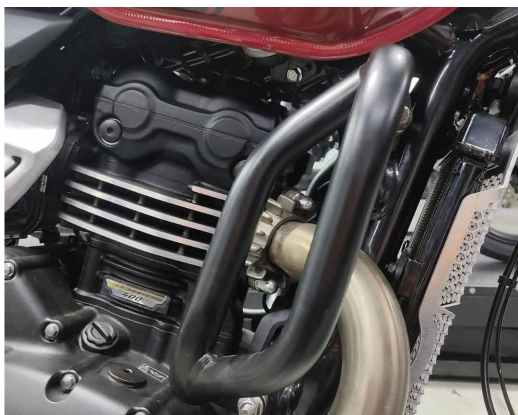

## PRODUCTO INSTALADO

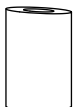
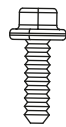
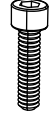
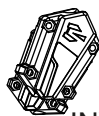

### EL KIT CONTIENE:

<b>Defensa Izquierda</b>  P1 CANTIDAD: 1	<b>Defensa Derecha</b>  P2 CANTIDAD: 1	<b>Buje ALT 14</b>  B1 CANTIDAD: 2	<b>Buje Alto 50</b>  B2 CANTIDAD: 2
<b>Hexagonal Flange M8x70</b>  T1 CANTIDAD: 2	<b>Socket M5x 20</b>  T2 CANTIDAD: 8	<b>Inyección Mastech</b>  INY1 CANTIDAD: 2	<b>Tuerca seguridad M5</b>  TU1 CANTIDAD: 8

### INSTALACIÓN:

**1** Desinstale los tornillos originales y el tornillo pasante inferior del motor.

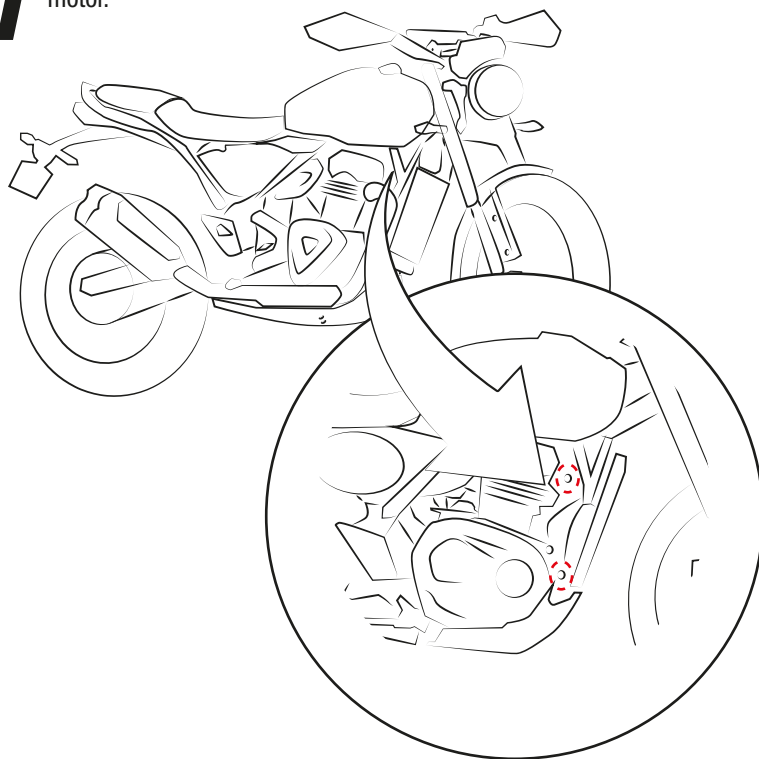



**2** Pre-ensamble la defensa derecha (P1), el buje (B2), el tornillo hexagonal M8x 70 (T1) y el buje (B1). Ensamblar en la motocicleta.

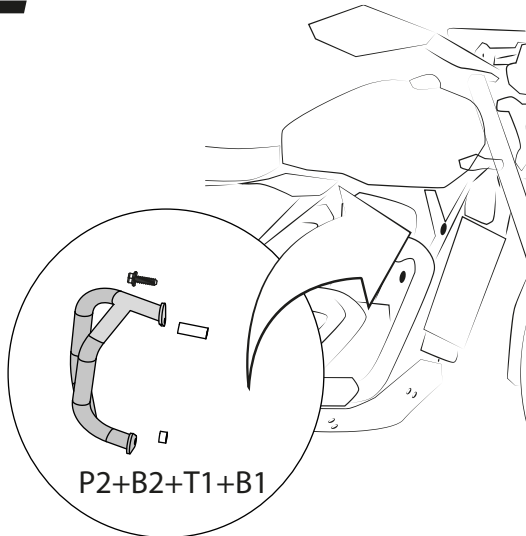

**3** Repetir el proceso en el lado izquierdo

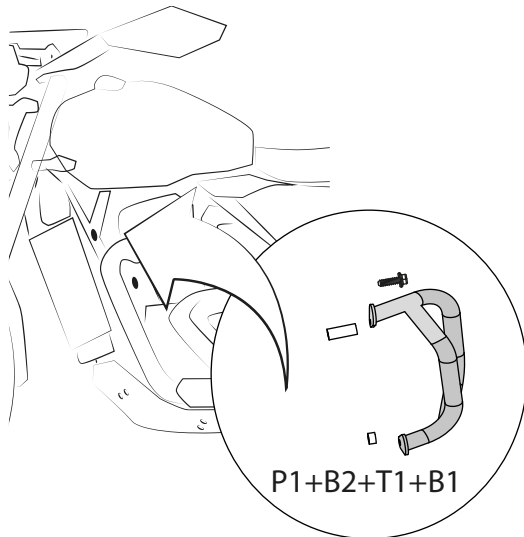

**4** Inserte el tornillo pasante y la tuerca original de la moto.

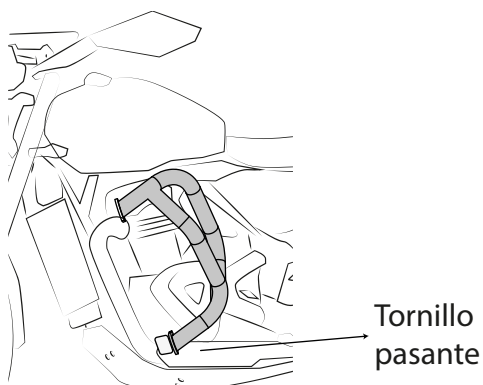

**5** Agregue la inyección (INY1), los tornillos socket M5x20 (T2) y las tuercas (TU1).

